

**Question 1 (10 Marks)**

Consider the following linear second order ODE

$$y'' + 7y = f(t).$$

modelling the dynamics of an undamped mass–spring system like that in Figure 1.

- (a) If the external force is zero, i.e.

$$f(t) = 0,$$

what is the frequency of natural oscillations,  $\omega_0$ , for this undamped system?

- (b) Now suppose that the external force is oscillatory and takes the form

$$f(t) = \sin(3t).$$

We know that to find the general solution to the nonhomogeneous ODE with this forcing we must first find the complementary function which has the form

$$y_{CF} = C_1 \sin(\omega_0 t) + C_2 \cos(\omega_0 t),$$

and then we should try to find a particular integral. Write down what form for the particular integral you should try (just write it down, there's no need to do any calculations).

- (c) Now suppose that the external force is oscillatory and takes the form

$$f(t) = \cos(\sqrt{7}t).$$

Write down what form for the particular integral you should use in this case (again, just write it down, there's no need to do any calculations).

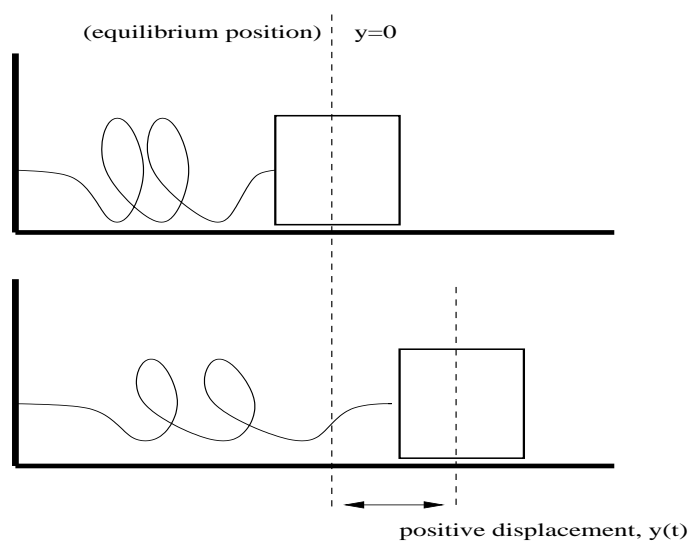

Figure 1: Simple undamped mass-spring system (question 1).

**Question 2 (15 Marks)**

Find the solution to the initial value problem:

$$y'' - 5y' + 4y = 3e^{-2t}, \quad y(0) = 1, \quad y'(0) = 0.$$

**Question 3 (10 Marks)**

Find the general solution of the differential equation

$$y'' + 6y' + 9y = 5e^{-3t}.$$

**Question 4 (10 Marks)**

(a) Find the Laplace transform of the function

$$f(t) = e^{-8t} \sin(3t),$$

stating any formula from the Laplace transform table you have used.

(b) Find the inverse Laplace transform of the function

$$\bar{f}(s) = \frac{1}{s^2 + 8s + 16}.$$

**Question 5 (15 Marks)**

Consider the damped spring system shown in Figure 2, which consists of a mass which slides on the horizontal surface, and is attached to a spring, which is fixed to a vertical wall at the other end. Suppose that the mass is acted upon by an external forcing function  $f(t)$ , so that the initial value problem for the motion of the mass is

$$y'' + 3y' + 2y = f(t), \quad \text{with } y(0) = 0, \quad y'(0) = 0. \quad (1)$$

Use the Laplace transform to determine the solution to this initial value problem in the case when the external force for all  $t \geq 0$  is

$$f(t) = \delta(t - 4), \quad (2)$$

i.e. the mass is given a sharp hammer blow at time  $t = 4$ . Sketch the behaviour of the solution for all  $t \geq 0$ .

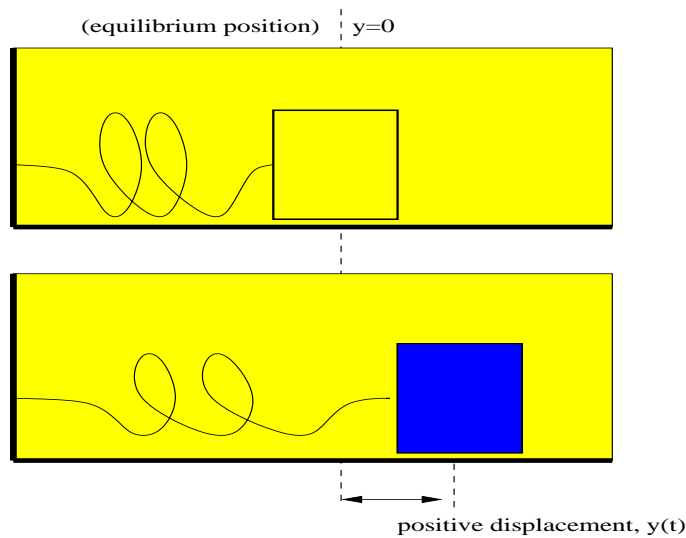

Figure 2: Simple damped mass-spring system (question 5).

**Question 6 (10 Marks)**

Consider the electrical circuit in figure 3.

Kirchoff's loop rule, Ohm's law and Kirchoff's node rule applied to the top closed loop, the bottom closed loop, and at node P (or Q if you prefer), respectively, tell us that the unknown currents,  $I_1$ ,  $I_2$  and  $I_3$ , in the electrical circuit in figure 3, satisfy the system of equations

$$\begin{aligned} 2I_1 + \frac{1}{2}I_3 &= 8, \\ 2I_2 + \frac{1}{2}I_3 &= 16, \\ I_1 + I_2 - I_3 &= 0. \end{aligned}$$

Use Gaussian elimination to solve the system of equations and determine  $I_1$ ,  $I_2$  and  $I_3$ .

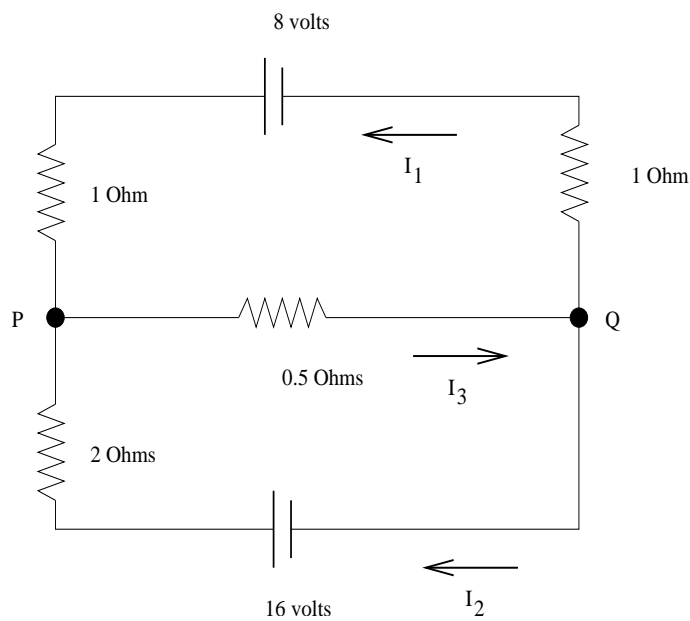

Figure 3: Complex electrical circuit in equilibrium (question 6).

**Question 7 (30 Marks)**

- (a) Show that  $-2$ ,  $-2 + \sqrt{2}$  and  $-2 - \sqrt{2}$  are the eigenvalues of the matrix

$$A = \begin{pmatrix} -2 & 1 & 0 \\ 1 & -2 & 1 \\ 0 & 1 & -2 \end{pmatrix}. \quad (4)$$

For each eigenvalue, find the corresponding eigenvector. **(15 marks)**

- (b) Three small beads, each having mass  $m = 0.1\text{Kg}$ , are spaced at equal intervals of length  $L = 1\text{m}$  on a very tightly stretched wire under tension  $T = 0.1\text{N}$ , as shown in Figure 4 (overleaf). Applying Newton's second law and Hooke's law, this bead-wire system gives rise to the differential equation system

$$\frac{d^2 Y}{dt^2} = AY, \quad (5)$$

where  $A$  is the matrix given in (4) above, and

$$Y = \begin{pmatrix} y_1 \\ y_2 \\ y_3 \end{pmatrix}$$

is the vector of unknown vertical position displacements (from equilibrium) for each of the beads shown in Figure 4 (overleaf). By looking for a solution of the form

$$Y(t) = Ce^{\lambda t}$$

for a constant vector  $C$ , show that solving the system of differential equations (5) reduces to solving the eigenvalue problem

$$(A - \lambda^2 I)C = O. \quad (6)$$

**(4 marks)**

- (c) We know from part (a) above that the solutions to this eigenvalue problem are  $\lambda_1^2 = -2$ ,  $\lambda_2^2 = -2 + \sqrt{2}$  and  $\lambda_3^2 = -2 - \sqrt{2}$ . Writing  $\lambda = i\omega$  so that  $\lambda^2 = -\omega^2$ , deduce the fundamental frequencies of oscillation  $\omega_1$ ,  $\omega_2$  and  $\omega_3$  of the mechanical system in Figure 4 (overleaf). **(3 marks)**
- (d) For each fundamental frequency of oscillation  $\omega_1$ ,  $\omega_2$  and  $\omega_3$  corresponding to  $\lambda_1$ ,  $\lambda_2$  and  $\lambda_3$ , the eigenvectors you deduced in part (a) above represent the possible modes of oscillation. Use those eigenvectors to enumerate the possible modes of oscillation of the beads corresponding to each eigenvalue-eigenvector pair. **(6 marks)**
- (e) Finally, write down the general solution of the system of equations (5). **(2 marks)**

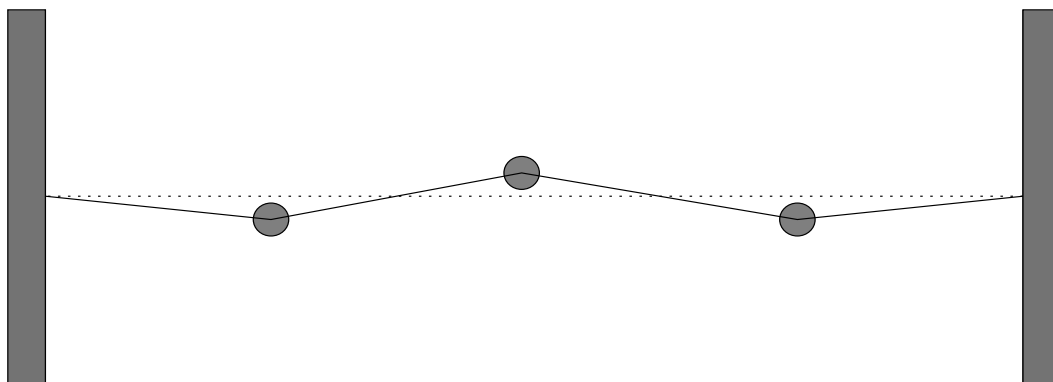

Figure 4: Simple bead-wire three-particle system (question 7).

$f(t)$	$\int_0^{\infty} e^{-st} f(t) dt$
1	$\frac{1}{s}$
$t^n$	$\frac{n!}{s^{n+1}}$
$e^{at}$	$\frac{1}{s-a}$
$\sin at$	$\frac{a}{s^2 + a^2}$
$\cos at$	$\frac{s}{s^2 + a^2}$
$af(t) + bg(t)$	$a\bar{f}(s) + b\bar{g}(s)$
$f'(t)$	$s\bar{f}(s) - f(0)$
$f''(t)$	$s^2\bar{f}(s) - sf(0) - f'(0)$
$e^{-at}f(t)$	$\bar{f}(s+a)$
$f(t) = \begin{cases} g(t-a), & t \geq a, \\ 0, & t < a, \end{cases}$	$e^{-sa}\bar{g}(s)$
$\delta(t-a)$	$e^{-sa}$
$f(t) * g(t)$	$f(s) \cdot g(s)$

Table 1: *Table of Laplace transforms.*